

GLÖTZL Baumeßtechnik

PLUMB WIRE DEVIATION PROBE GLAS-1

Type: GLAS-0.5 (1)

Art. No.: 82.90

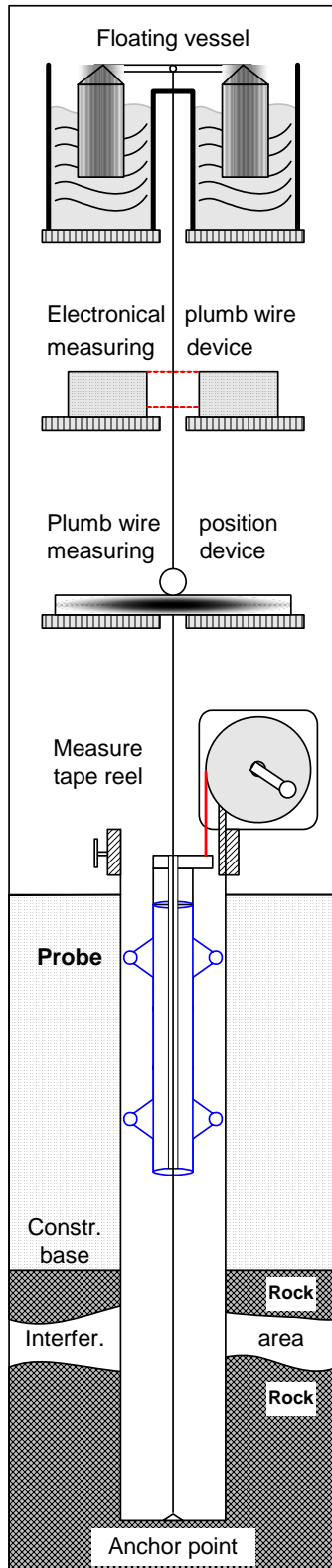

- robust
- easy to handle
- mechanical function
- no electronics
- comprehensible system
- high precision
- can be used in tubes up to Ø150mm

The plumb deviation probe GLAS has been developed for recording of horizontal movements and deformations of pipings of deeply founded floating plumb anchorings.

Floating plumbs in adequate execution can be measured in several levels. A number of electronic and manual measuring instruments are available for this purpose. As result, you will get the statement of construction movements in the two measuring axes, referred to the anchoring point of plumb wire. When using a floating plumb, however, the movements arising below the foundation base of construction, are and remain unknown.

For this reason, the anchorings for floating plumb are arranged deeply below the foundation base, up to 1.5-fold of the wall height and in geologically secured range below boundary surfaces and interference areas.

By the arrangement of inclination measuring levels, it is possible to record the movement course in the underground for compensation purposes, for which – however – a further boring is required which must not really correspond to the presuppositions and influence of the plumb boring.

In order to separate the behaviour and influence of underground from pure construction deformation, it is absolutely necessary to record the deformations by measuring method from foundation base till anchor point of plumb wire.

The plumb deviation probe has been developed for this application which allows to record the arisen horizontal movements in the plumb wire piping by means of inclination sensors. By central, precise guide of the plumb wire in the probe, it is also possible to record the plumb wire deviation by means of the installed electronic- or manual measuring instruments.

Figure 1:

The assemblage of measuring equipment is shown in the presentation opposite. The plumb deviation probe is following the position of piping. The thus resulting inclination measuring values are recorded as traverse in measuring steps of same length. Thus, the position of piping and its change during sequence measurements can be represented with high precision. At the same time, the deviations at plumb wire can also be recorded with the electronic measuring device, either abundantly or as single solution.



Description:

The plumb wire deviation probe is available in lengths of 0.5 and 1 m. The probe is equipped with two triple roller guides which are operating restricted guided. By this, it is secured that the probe is guided exactly concentrically and also is leading the plumb wire centrally in the piping. For this purpose, the probe is notched so that the plumb wire is passing the probe unimpededly and is only guided and deviated by the central roller guide according to deformation of piping.

Measurement:

The probe is inserted into the piping guided by plumb wire. The guide rollers of the plumb wire, which have to be correlated to the diameter of wire, are closed and the probe is lowered down to the boring base by measure tape. For probes with inclination sensors, this is done by the measuring cable.

The first measuring point is located in a selected depth and is displaced by a probe length towards the top after recording of deviation. The damping of measured value can be followed up at the inclination sensors resp. at electronic plumb wire measuring device. In order to receive a higher measuring accuracy, it is recommended to repeat the measurement, if possible in the same measuring direction.

Technical data:

Probe length without inclination sensors
 type GLAS 86/140/ 0.5 m long
 type GLAS 86/140/ 1 m long

Probe as before, but equipped with inclination sensors, with the designation GLASN (N as addition)

Tube diameter standard from 86 up to 140 mm; further dimensions on request

Meas. accuracy at repeated double measurement better 0.2 mm each meas. step at high quality and correctness of piping

Material of probe brass chromium-plated
 Weight approx. 3.5 kgs

Required tube excess length to fixing of measure tape reel 200 mm

Measure tape reel with gear reduction and locking brake equipment

Measure tape length 50 m

Figure 2, on the left:

Plumb wire deviation probe complete with 2 pcs. triple roller guides forced centered

Figure 3:

Head part of probe with roller guide for centering of plumb wire



Figure 4:

Head point of probe with triple roller guide and traction rope connection



Figure 5:

Base of probe with triple roller guide

